

ST23 Steam Boiler

1000-6000 kg/hour

Developed from the world-renowned and extremely popular Wee Chieftain boiler, the ST23 is a packaged steam boiler that utilises a horizontal three pass wet back design constructed in accordance with BS EN 12953. This unit offers a smaller footprint whilst maintaining high efficiency and performance, with low NO_x options.

It complies with the requirements of the Factories Act (1961) and Guidance on Safe Operation of Boilers Ref: BG01 developed by the Safety Assessment Federation (SAFED) and the Combustion Engineering Association (CEA). In addition, the ST23 is UKCA, UKNI+CE or CE marked to meet the requirements of the Pressure Equipment Directive (PED), Low Voltage; Electro-Magnetic Compliance & Machinery Safety Directives. Throughout the manufacturing process, this boiler is subject to inspection by a leading Independent Insurance Company, in addition to Cochran's own ISO 9001-compliant quality procedures.

Cochran's ST23 packaged steam boiler offers the following key features and optional upgrades:

- Capable of achieving NO_x emissions of 100 mg/Nm³ for natural gas firing.
- Compact design results in an economical footprint.
- Output range of 1000 kg/hr to 6000 kg/hr F&A 100°C at a nett efficiency of up to 95% in accordance with EN12953.
- Fully matched with Cochran oil, natural gas or dual firing combustion equipment.
- Wide range of combustion and control packages and economiser options.
- Turndown of up to 6:1.
- Cochran Eclipse or Synergy Touchscreen HMI with Modbus interface and remote access capability.
- Variable speed drives for FD Fan and Feed water pump motors help deliver low noise levels and reduce power consumption.
- Enhanced insulation for lower touch temperature.



ST23 Steam Boiler

1000-6000 kg/hour

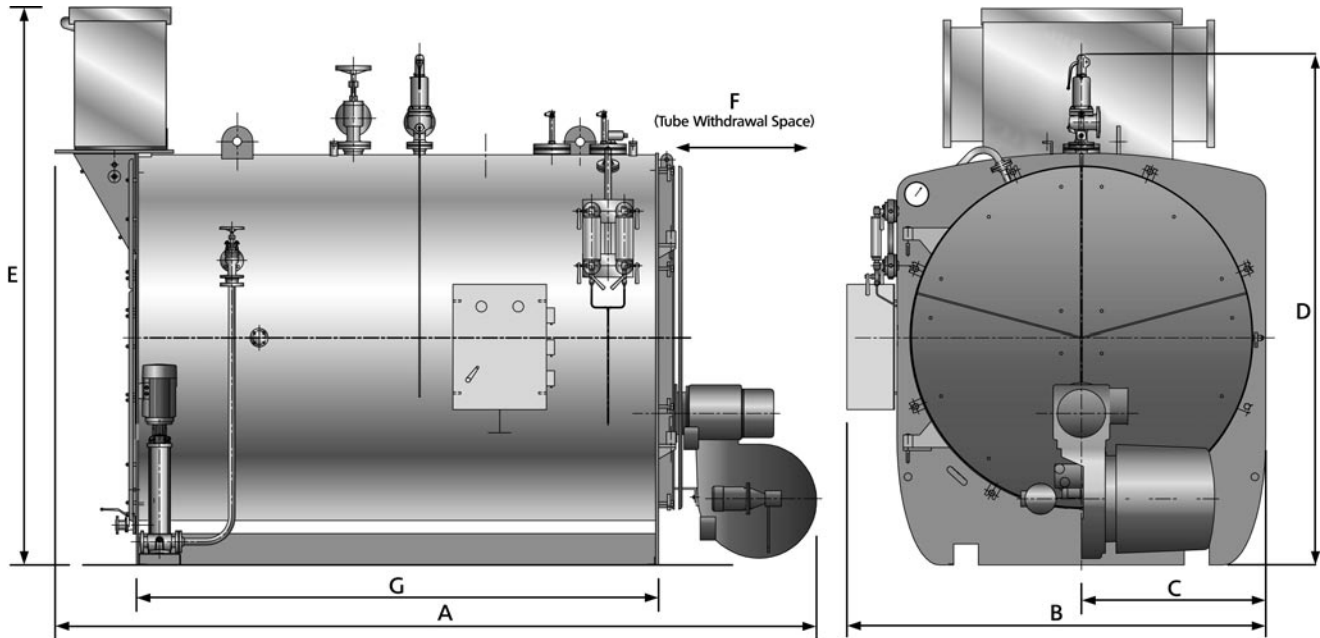

ST23 Boiler Model			ST23-1.0	ST23-1.5	ST23-2.0	ST23-2.5	ST23-3.0	ST23-3.5	ST23-4.0	ST23-4.5	ST23-5.0	ST23-5.6	ST23-6.0	
Evaporation		kW	627	940	1254	1567	1881	2194	2507	2821	3134	3510	3761	
F&A 100°C (212°F)		kg/h	1000	1500	2000	2500	3000	3500	4000	4500	5000	5600	6000	
		lb/h	2205	3307	4409	5512	6614	7716	8818	9921	11023	12346	13228	
Dimensions	Oil	A	mm	3145	3763	3763	4347	4391	4391	4896	4901	5414	5838	6176
		Nat.Gas	A	mm	3355	3953	3953	4552	4727	4753	5009	5009	5522	5951
		B	mm	1901	2101	2101	2486	2637	2637	2690	2690	2845	2845	3671
		C	mm	781	881	881	1073	1149	1149	1184	1184	1250	1250	1250
		D	mm	2153	2413	2413	2882	3034	3034	3251	3251	3366	3394	3394
		E	mm	2251	2646	2646	3030	3297	3297	3442	3442	3689	3690	3690
Boiler Tube Withdrawal	F	mm	1980	2440	2440	2964	2950	2950	3170	3170	3650	3980	4205	
	G	mm	2153	2633	2633	3154	3140	3140	3360	3360	3840	4233	4456	
Recommended Chimney Dia.		mm	230	280	305	355	380	405	430	455	485	510	535	
Safety Valve Exhaust Dia.		mm	40	50	50	65	65	65	80	80	80	100	100	
Steam Stop Valve Dia.		mm	50	65	65	80	100	100	100	100	100	125	125	
Blow Down Valve Dia.		mm	25	25	25	25	25	25	25	25	25	25	25	
Feed Check Valve Dia.		mm	25	25	25	25	40	40	40	40	40	40	40	
Feed Pump Inlet Dia.		mm	25	25	25	25	25	25	25	25	25	32	32	
Feed Water Strainer Dia.		mm	25	25	25	25	40	40	40	40	40	40	40	
Oil Inlet Connection Dia.	B.S.P.		3/8"	3/8"	3/8"	3/8"	3/8"	1"	1"	1"	1"	1"	1"	
Boiler Weight-Empty		Tonnes	3.70	5.00	5.10	8.10	9.20	9.20	11.30	11.40	14.20	14.42	16.82	
Weight to N.W.L.		Tonnes	5.20	7.40	7.50	13.30	14.90	14.90	17.60	17.70	22.70	23.88	26.74	
Weight full of Water		Tonnes	5.60	8.00	8.10	14.40	16.30	16.30	19.20	19.30	24.70	26.10	28.74	

Note: All Dimensions and weights are approximate only and are based on a boiler working pressure of 10 BarG, other design pressures available.
Table data includes use of an economiser, but no gas bypass.

+44(0) 1461 202 111 www.cochran.co.uk

Newbie Works, Annan, Dumfries & Galloway, UK DG12 5QU.

Whilst this information is given in good faith, no warranty or representation is given concerning such information which must not be taken as establishing any contractual or other commitment binding upon Cochran Group Ltd Company or any of its subsidiary associated companies. ©2024 Cochran Ltd. Version 3 11/24

